

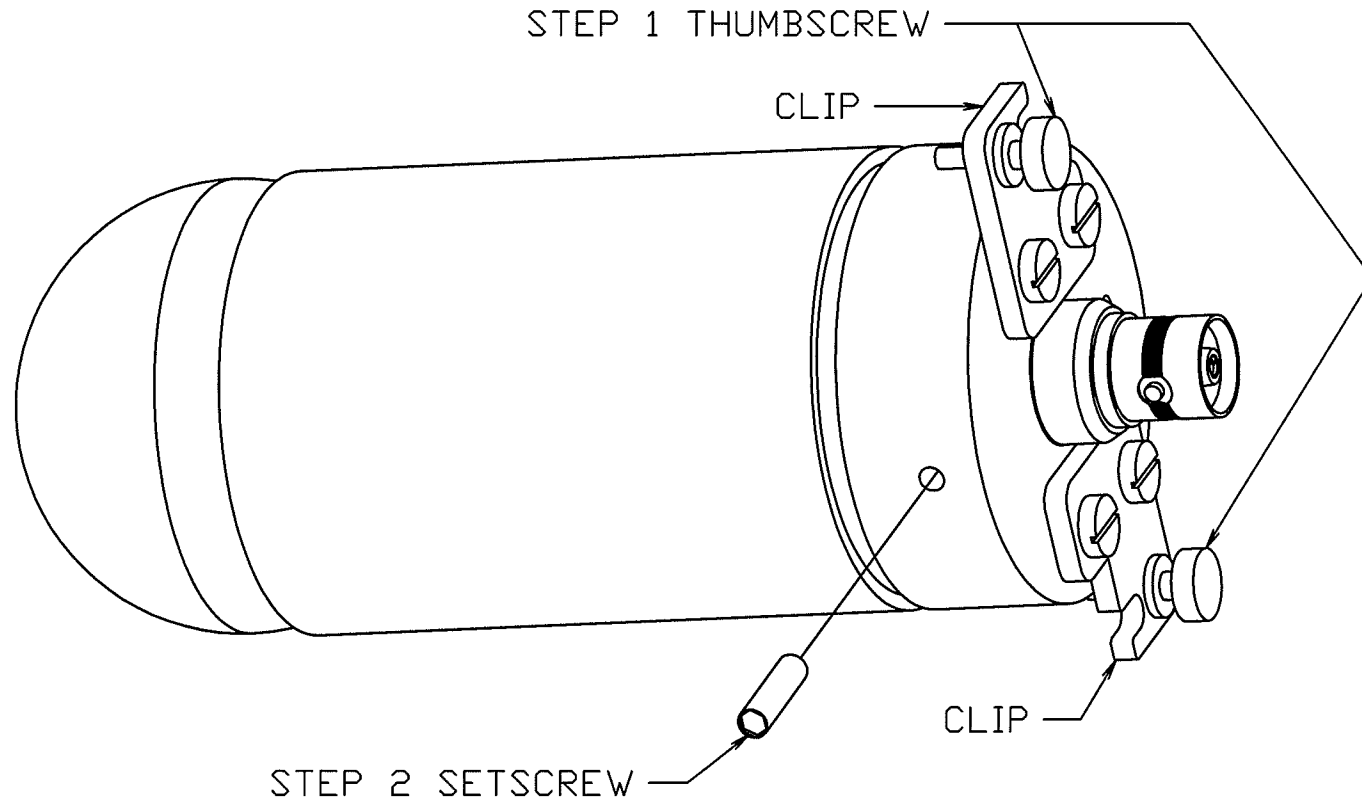

REV #	ALTERATIONS	DATE	BY
1	VALID	10/30/06	PW



STEP 1-REMOVE THIS SECTION FROM THE POLYETHYLENE BALL BY REMOVING THE TWO THUMBSCREWS AND PULLING THIS SECTION OUT BY THE CLIPS.  
STEP 2-REMOVE THE SETSCREW FROM THE SIDE WITH A 1/8" ALLEN HEX WRENCH.

DWN PW	DATE 10/30/06	CHK	DATE	APP. DATE 10/30/06
DWG NUM: 4005-023		SCALE: FULL <input checked="" type="checkbox"/> OTHER		
TITLE M 42-31 BF3 TUBE REMOVAL				
 LUDLUM MEASUREMENTS, INC. 501 DMK STREET SWEETWATER, TEXAS 79556		SERIES 5	SHEET 17B	

REV #	ALTERATIONS	DATE	BY
1	VALID	10/30/06	PW

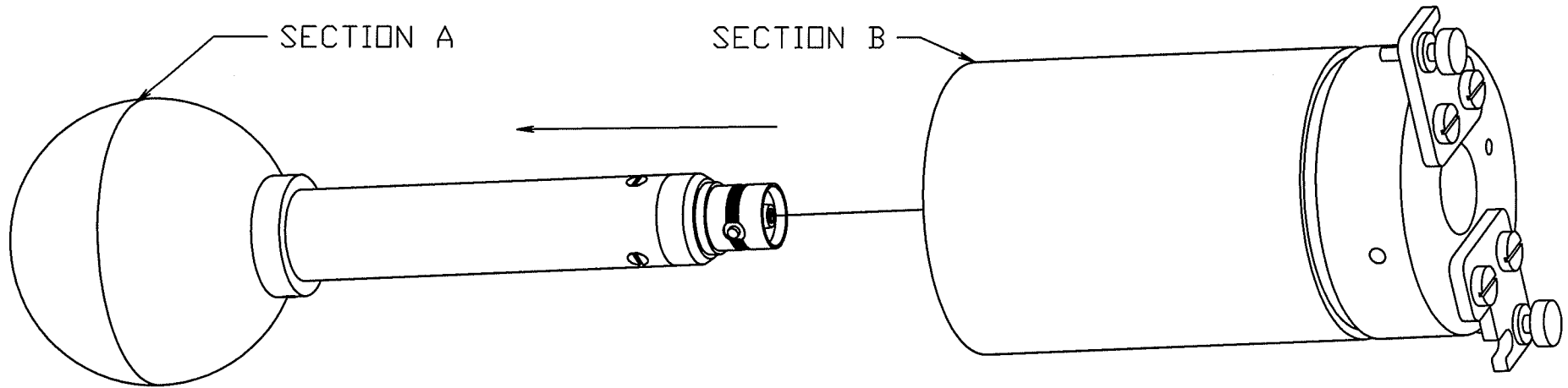

STEP 3-REMOVE SECTION A FROM SECTION B.

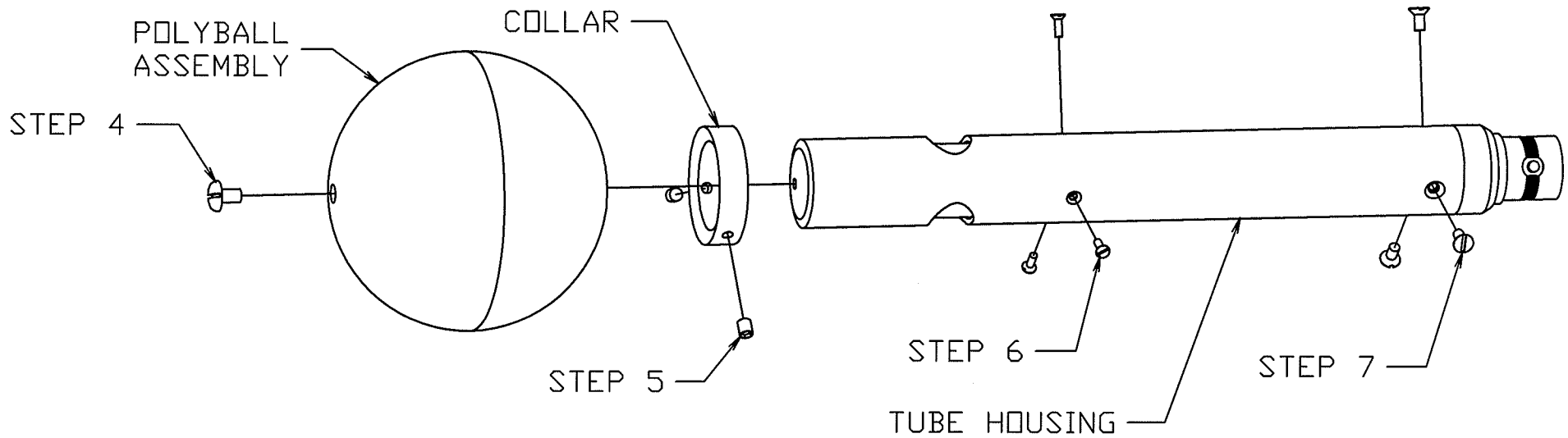

STEP 4-REMOVE SCREW FROM END OF POLYBALL ASSEMBLY AND REMOVE POLYBALL ASSEMBLY.

STEP 5-REMOVE SETSCREWS FROM THE COLLAR USING A 1/16 ALLEN HEX WRENCH AND REMOVE COLLAR.

STEP 6-REMOVE 2-56 SCREWS (3 EA.) FROM TUBE HOUSING.

STEP 7-REMOVE 4-40 SCREWS (3 EA.) FROM TUBE HOUSING.

DWN	DATE	CHK	DATE	APP	DATE
PW	10/30/06			<i>PW</i>	10/30/06
DWG NUM: 4005-023			SCALE: FULL <input checked="" type="checkbox"/> OTHER		
TITLE M 42-31 TUBE REMOVAL					
 LUDLUM MEASUREMENTS, INC. 501 DWK STREET SWEETWATER, TEXAS 79556			SERIES	SHEET	
			5	17C	

REV #	ALTERATIONS	DATE	BY
1	VALID	10/30/06	PW

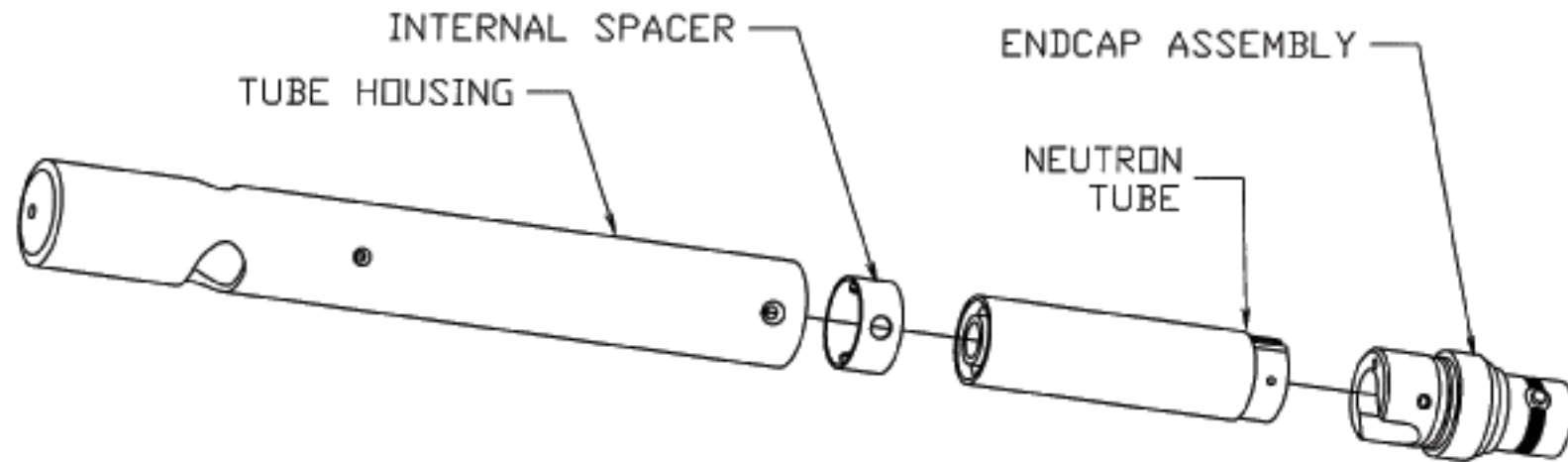

STEP 8-REMOVE ENDCAP ASSEMBLY, NEUTRON TUBE AND INTERNAL SPACER FROM TUBE HOUSING.  
 STEP 9-UNSOLDER THE WIRES FROM NEUTRON TUBE AND DISPOSE OF NEUTRON TUBE PER LOCAL,  
 STATE AND FEDERAL REGULATIONS.

STEP 10-REASSEMBLE THE DETECTOR WITHOUT THE NEUTRON TUBE IN REVERSE ORDER AND SHIP  
 THE MODEL 42-31 WITH THE MODEL 12-4 BACK TO  
 LUDLUM MEASUREMENTS INC.  
 ATTEN: REPAIR DEPARTMENT  
 501 OAK ST.  
 SWEETWATER TX 79556

\*

NO RMA NUMBER IS NEEDED BUT A NOTE WITH A CONTACT NAME AND PHONE NUMBER IS.

OWN	DATE	CHK	DATE	APP. DATE
PW	10/30/06			10/30/06
DWG NUM	4005-023	SCALE	FULL	OTHER
TITLE M 42-31 TUBE REMOVAL				
LUDLUM MEASUREMENTS, INC. 501 OAK STREET SWEETWATER, TEXAS 79556		SERIES	SHEET	
		5	17D	